

GRINDER

SERIES **410**

TECHNICAL INFORMATION

Capacity:	20 000 kg/h
Motor:	up to 90 kW
Transmission:	V-belt
Dia. of hole plate:	412 mm.
Dia. of feed screw:	394 mm
Total length:	2400 mm
Total width:	2305 mm
Total height:	2200 mm
Net weight:	1900-2300 kg

KNIVES

Choice of one or two knives depending on the product to be ground and the desired fineness of grind.

HOLE PLATES

Hole plates are available in most existing hole diameters and designs.

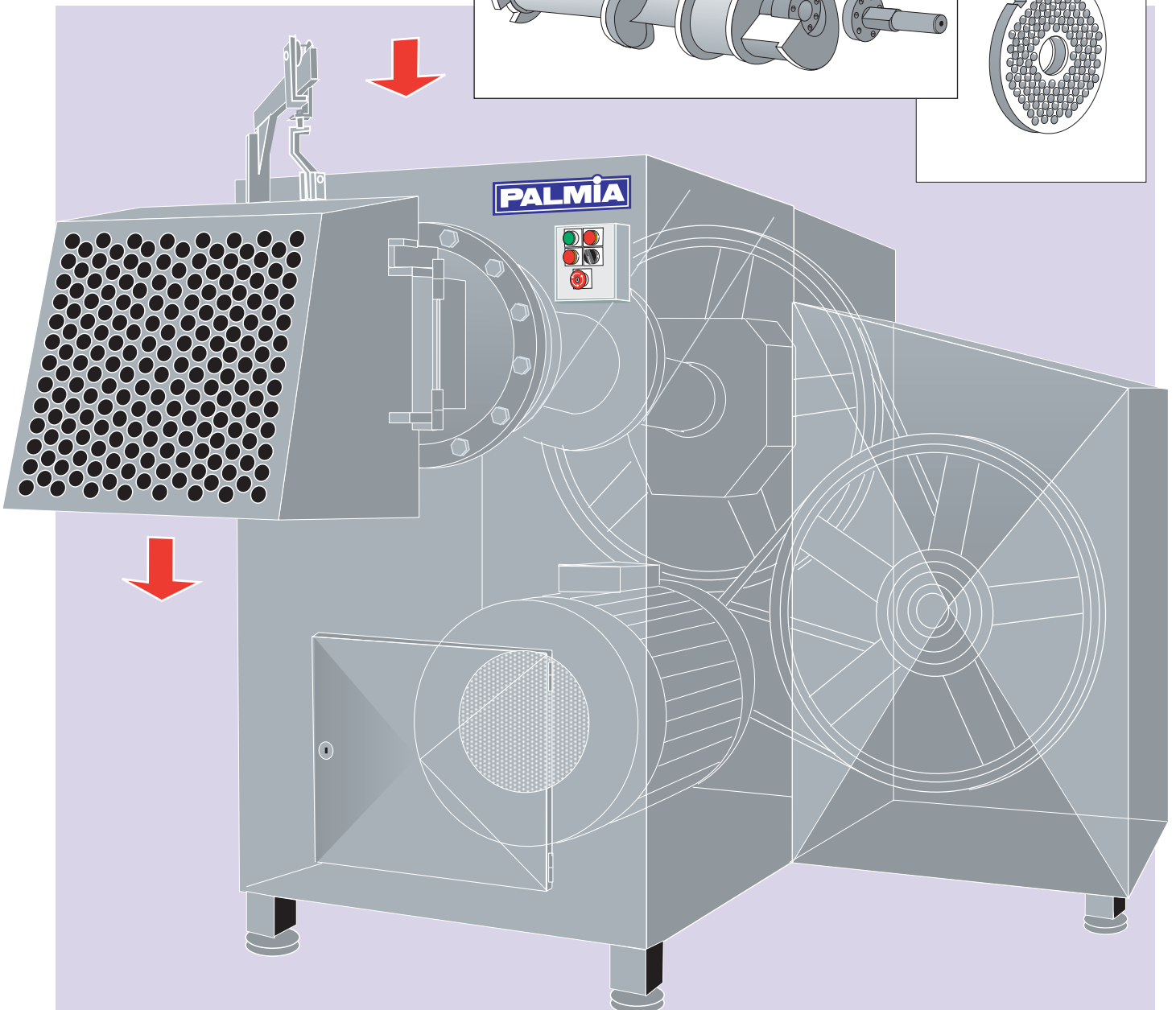
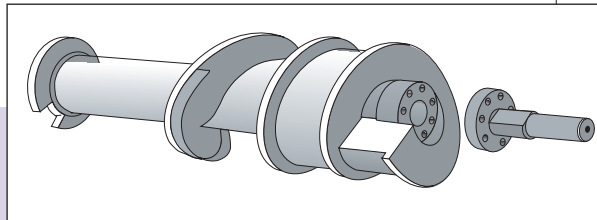
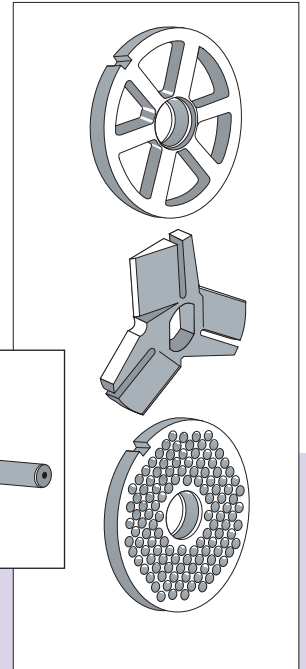

GRINDER

SERIES 410

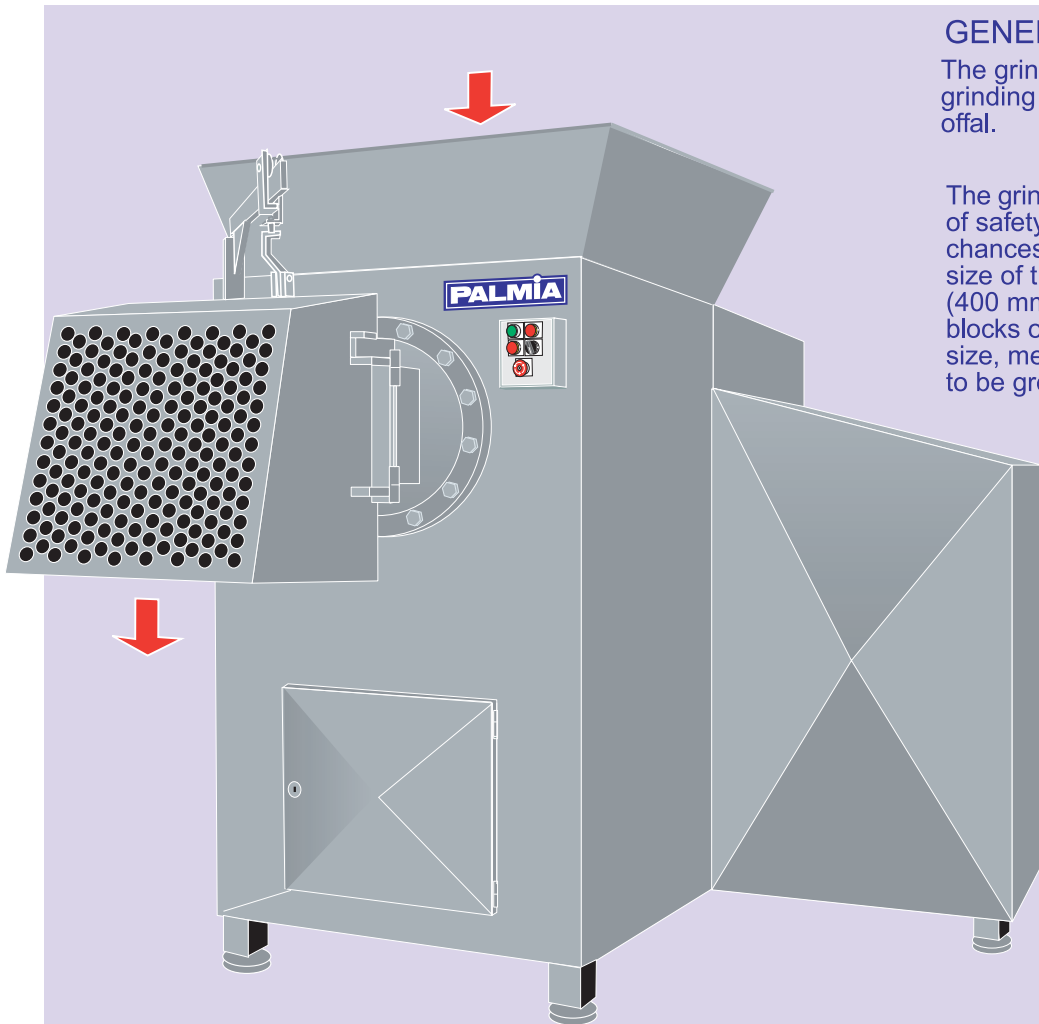

GENERAL

The grinder is used specially for the grinding of bones and slaughterhouse offal.

The grinder can be obtained with a variety of safety features to eliminate the chances of worker injury. The generous size of the hopper and the feed screw (400 mm dia.) allow standard frozen blocks of up to 800 x 600 x 200 mm in size, meat or fish, to be ground.

The grinders are available with a stainless or enamelled finish or a combination of both.

EXTRA ACCESSORIES

Complete electrical circuitry incorporated in the chassis.
Extra hopper.
Lifting mechanism for feeding.
Facility for melting tube or boiling tube with direct steam.

Palmiatek Oy Ltd

Sepänpellontie 19
28430 PORI, FINLAND
Tel. +358 207 559 100
Fax. +358 2 550 7350
E-mail: palmia@palmiatek.fi

